

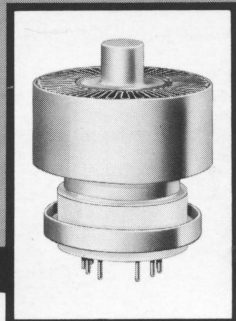

HAM TIPS



A PUBLICATION OF RCA ELECTRONIC COMPONENTS AND DEVICES

VOL. 24, NO. 1

©1964, RADIO CORPORATION OF AMERICA

WINTER, 1963-64

300-Watt-Output, 432-Mc Amplifier Utilizes RCA-8122 for Class C Operation

By John M. Filipczak, K2BTM*

RCA Electronic Components and Devices

The author considers the RCA-8122 an ideal choice for use as a class C amplifier in transmitters operating in the frequency range from 400 to 500 megacycles.

One of the most versatile and reliable beam-power tubes ever offered to promote high-efficiency operation on amateur UHF, this ceramic-metal type offers the ham outstanding performance characteristics at an attractive price.

Ceramic-metal construction, combined with RCA's exclusive grid-making technique for precision grid alignment, afford this tube exceptional structural and electrical stability.

Featuring a 13.5-volt heater and rated for CW and linear rf service, the 8122 is intended for either mobile or fixed-station operation. High-perveance design helps achieve UHF power output at relatively low plate voltages. At an operating frequency of 470 megacycles, a plate voltage of 2,000 volts, and a current of 0.3 ampere, useful CW power output is 300 watts.

Reduced tube size and increased heat-handling capability further enhance the value of the 8122 in compact, mobile transmitters where space is at a premium.

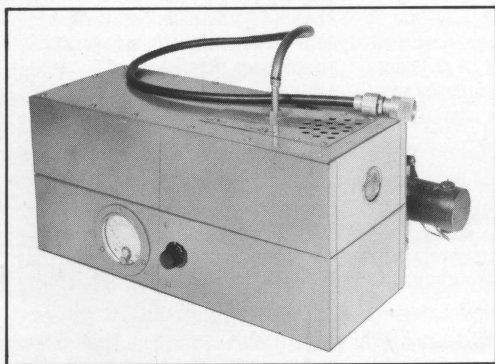

K2BTM's low-cost, 300-watt, 432-Mc amplifier.

Design Features

Figure 1 shows the package layout and Figure 2 the schematic for an RCA-8122 in a class C amplifier designed to operate at 432 megacycles. At this frequency, the output circuit is effectively isolated from the input circuit by the low-inductance ring terminal attached to grid No. 2. Input admittance at the high frequencies is reduced by three separate cathode leads which provide a low-inductance rf path to ground. One of the cathode leads—preferably the one from the No. 4 pin—can be series-tuned to ground with a small trimmer capacitor. This provides an additional means for broadband neutralization in the upper frequency range of the tube.

The amplifier was designed to be driven by

*Commercial Receiving Tube and Semiconductor Division, Harrison, N. J.

300 watts of rf power output (at frequencies up to 470 megacycles) for an input driving power of only 5 watts. It is designed to operate with plate voltages from 700 volts (for 100-watt power output) to 2,000 volts (for 300-watt power output). The high power outputs achieved from relatively low plate voltages and driving power are made possible by the tube's high power sensitivity and perseverance.

The RCA-8122 requires forced-air cooling during operation. The combined effect of this cooling, plus the heat dissipation capability from its highly efficient radiator, permits the tube to be operated at a maximum plate dissipation of 400 watts without any sacrifice in reliability. At this plate dissipation, the radiator-core temperature is rated at 250° C for the tube's specified air flow of 6½ cubic feet per minute. The radiator-core temperature at maximum plate dissipation can be substantially reduced, however, if the rate of cooling is increased. The blower for the 8122 may be any one of the smaller, commercially available types.

Circuit Details

The control grid (grid No. 1) of the amplifier tube is connected to a half-wavelength strip line which is tuned at its open end by a glass-type piston-adjusted capacitor. This grid line is made from a piece of flat copper 1/8-inch thick which reduces rf losses and helps maintain the grid temperature at a safe level.

A combination of fixed (10.5-volt battery) and grid-leak bias is used in the circuit. The fixed bias makes certain that the tube will be operated within a safe range of dissipation should the driving power fail. The input-coupling link (L₁) is series-tuned to reduce reactance and provide optimum coupling between the driver and grid No. 1 of the 8122.

Cathode pins 1 and 9 are grounded to the chassis. The remaining cathode pin (No. 4) is then series-tuned to ground with a small trimmer capacitor to provide the required neutralization adjustment at 432 megacycles.

The screen grid (grid No. 2) is bypassed to ground at the operating frequency by a screen-ring capacitor (E. F. Johnson type No. 124-113-1 or equivalent). Additional neutralization of the amplifier circuit may be obtained by eliminating one or more of the screen-ring contact fingers. This effect is most easily accomplished by separating the contact finger from the screen-ring terminal on the tube with 0.01-inch-thick Teflon strips. The number of fingers that must be insulated is determined by the compensation necessary to

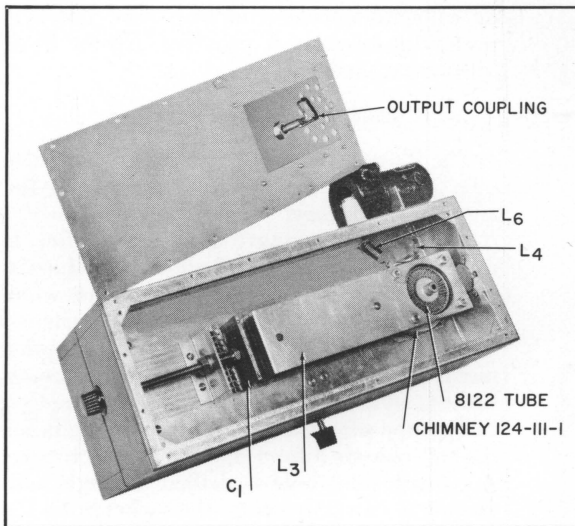

Top view of amplifier showing plate-line assembly.

obtain complete neutralization. Requirements for neutralization vary among different amplifiers. In some cases, none of the contact fingers need be insulated. In any event, since insulation can be easily added after the package has been completely assembled, it should be avoided unless shown absolutely necessary by a neutralization check.

The plate line is the most critical part of the amplifier circuit, and must maintain low-loss contact with the plate to insure satisfactory performance at the desired operating frequency. The plate line is a half-wavelength strip line tuned at its open end by a specially constructed tuning capacitor. This capacitor, C₁, is shown in Figure 1, and the details of its construction are outlined in the section that follows.

Power may be transferred from the plate line to the load through either a link coupling

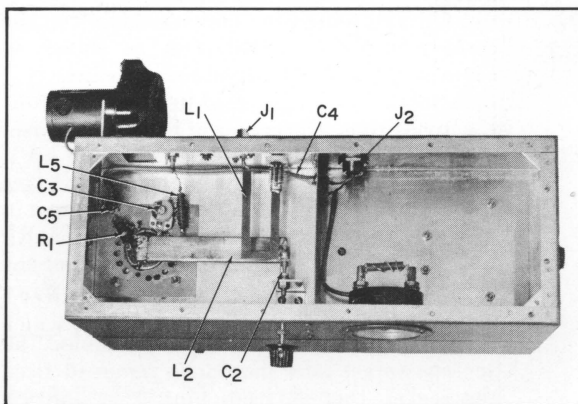

Bottom view of amplifier showing grid-No. 1 assembly.

or capacitive-probe coupling. The latter is preferable because it provides greater flexibility of adjustment.

Mechanical Construction

The illustrations accompanying this article offer data you need for construction of the amplifier "package."

As shown in Figure 1, the amplifier is mounted in two standard aluminum chassis, each of which is 13 inches long, 5 inches wide, and 3 inches deep. The chassis are fastened back-to-back to provide separate compartments for the grid and plate lines. Thus attached, all mounting holes with the exception of the tube-socket holes (whose diameters for the two chassis differ) may be drilled to size. A 1/8-inch pilot hole is drilled through both chassis to correctly center the socket holes for accurate punching to final size. After all mounting holes have been drilled, the chassis are detached from each other, and holes for the tube socket punched in each chassis. This can be done in the sizes required with Greenlee type of socket punches. The outline of the plate chassis (Figure 3) indicates the sizes and locations of the socket holes for both chassis. The ventilation holes surrounding the socket holes should be punched through both chassis while they are fastened together. Locations and sizes of all other chassis holes are shown in Figures 1 and 4.

All electrical ground connections are soldered to a piece of flashing copper which surrounds the base of the tube socket. This piece of copper is held to the base of the grid-line compartment by the four No. 6-32 screws that also hold the E. F. Johnson screen bypass ring, which is located in the plate-line compartment.

The grid-No. 1 line is held in place by soldering one end to the tab of the piston capacitor, C_2 . The remaining end is soldered to the three grid-No. 1 socket pins, as shown in Figures 1 and 4. An aluminum bracket, 1/16-inch thick, holds the grid-tuning capacitor, C_2 , in position. The center of C_2 and the bushing holding the tuning shaft must line up if smooth tuning is to be obtained. A shield (see Figure 1) is placed in the grid compartment to isolate the grid-current meter from the RF field. The shield also reduces the size of the grid section, thereby increasing the efficiency of "pressurized" cooling.

Before the tube socket is assembled, all screen-contact tabs should be removed from the socket—that is, from pins 2, 7, and 10. The dc connection to the screen grid is made

in the plate compartment. Figure 5 shows the method used for the dc connection to the screen grid.

Details for the construction of the plate line are shown in Figures 1 and 6. The bracket assembly that guides the No. 1/4-20 threaded plate-capacitor tuning shaft should be constructed close to the dimensions shown in Figure 7. An improperly constructed bracket will result in an erratic ground for the plate-tuning assembly. The distance of the plate line from the ground reference should be the required 1 1/2 inches. This distance provides the correct surge impedance and resonant frequency of the strip line with the top cover in place.

The B+ choke is connected to the plate line by one of the screws which hold the plate assembly together. This connection is shown in the photograph on page 3. The B+ choke is connected at the low-voltage, high-current point of the plate line. The output-coupling probe shown in Figure 8(a) is located in this area. The specially constructed high-voltage bypass capacitor consists of a 1/32-inch brass plate insulated from the chassis by a 0.006-inch-thick piece of mica insulation (see Figure 9). The value of the bypass capacitance is sufficiently great to make it essentially a short circuit at the operating frequency.

The 1/4-inch shaft-lock bushings are also used for guiding the shaft for the plate-tuning capacitor. These bushings (No. 181, Herman L. Smith, Inc., or equiv.) are ideal for this application because they can be adjusted to provide the amount of "drag" or tension required to sustain a good contact.

The soldering of the finger stock to the plate assembly can be simplified by use of a tapered wooden plug as shown in Figure 10. The plug will hold the finger stock in place and prevent excessive heat absorption during the soldering operation.

Operation and Tuning

Adherence to the following procedures and instructions is recommended to assure safe and satisfactory operation of the amplifier circuit:

1. All plate-supply voltages in the range specified for the operation of the RCA-8122 are high enough to represent a potential danger to human life. Therefore, as a safety precaution, all supply voltages should be interlocked.

2. In the proposed application, the heater power for the RCA-8122 should be 12.5 volts, ac or dc, at 1.3 amperes. After the heater

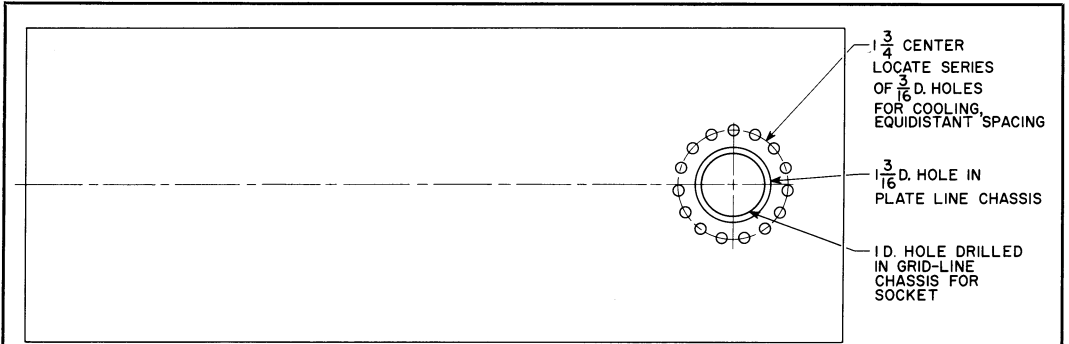

Figure 3(a): Details of vent and socket holes.

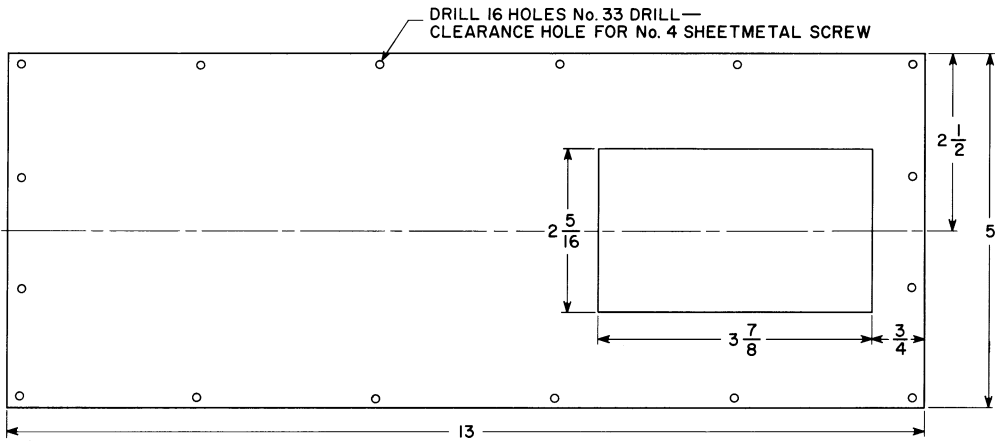

Figure 3(b): Details of top cover for plate-line chassis.

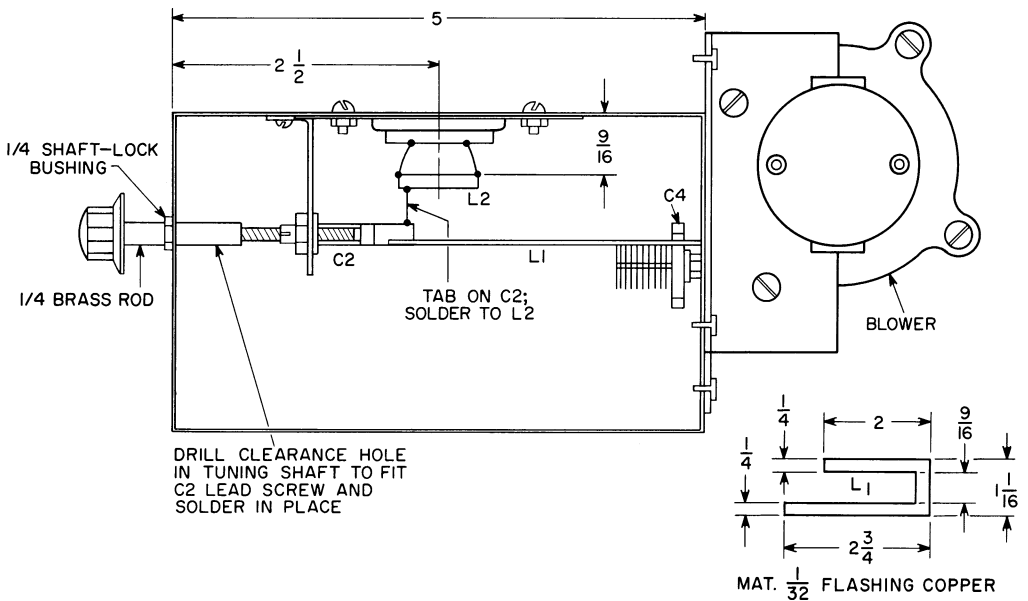

Figure 4: Side view of grid-No. 1 compartment, including details of L₁ construction.

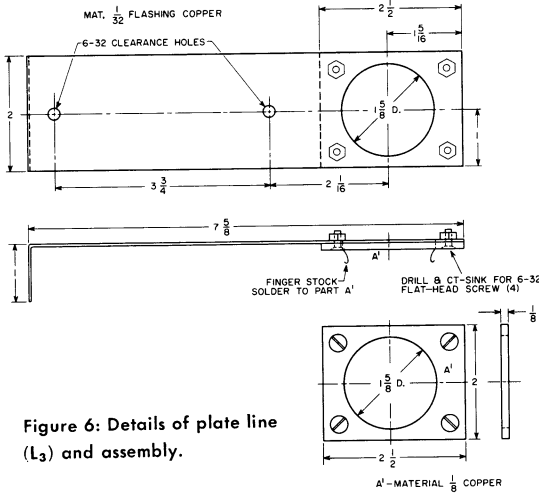

Figure 6: Details of plate line (L₁) and assembly.

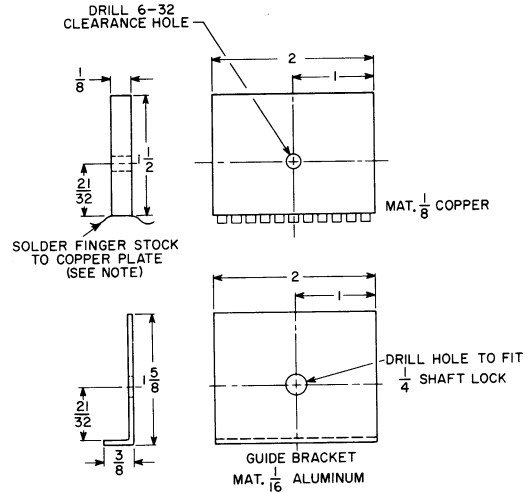
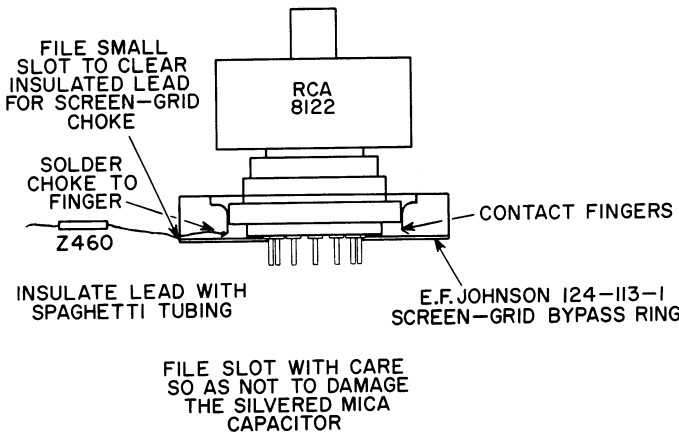

Figure 7: Details of C₁ construction.



Note: beryllium finger stock (Instrument Specialties Co., Inc., 97-115 or equivalent).

Figure 5: Procedure for making electrical connection to grid No. 2.

power is applied, the tube should be allowed to warm up for at least one minute before the plate voltage is applied. This procedure will help assure substantially longer tube life.

3. All tests for neutralization and tuning should be made with both grid- and plate-compartment covers in place.

The general procedure for preparing the amplifier for operation is as follows:

After a sufficient heater-warmup period has been allowed, the driving power is applied to the amplifier circuit without plate or screen-grid voltage supplied to the tube. The grid-No. 1 current meter should indicate approximately 30 to 35 milliamperes of current for 5 watts of drive power. If the grid current is insufficient, the following adjustments should be made:

1. The cathode neutralizing capacitor, C₃, should be adjusted for maximum grid current. Approximately one-half the total capacitance should be sufficient to provide the required indication, although further adjustments of C₃ may be necessary upon application of plate and screen-grid voltages.

2. Position the input-coupling link, L₁, for maximum grid current and a minimum input standing-wave ratio. The grid-line tuning capacitor, C₂, and the input-line capacitor, C₄, must be adjusted simultaneously with the positioning of L₁ with respect to the grid line. A standing-wave-ratio bridge inserted between the driver and L₁ will make the preceding adjustments much simpler.

After the input coupling has been properly adjusted, a preliminary check of the ampli-

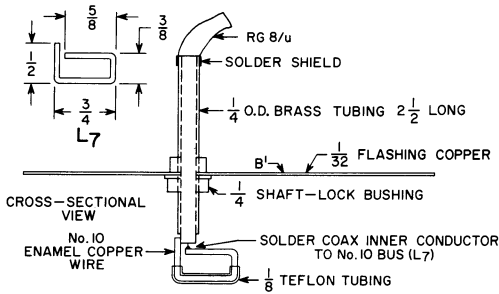

STRIP COAX CABLE FROM END $2\frac{3}{4}$.
 COMB, BRAID BACK, AND INSERT INNER
 POLY. INSULATOR THROUGH BRASS TUBE;
 SOLDER BRAID AND No.10 BUS (L7) IN PLACE.

Figure 8(a): Construction details for coupling probe.

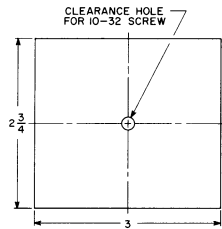

Figure 9: Details of high-voltage capacitor.

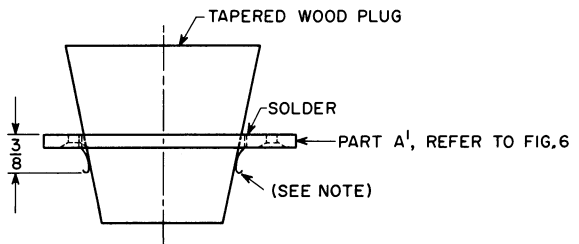
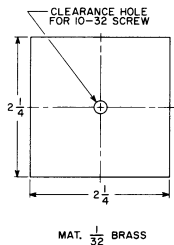

Figure 10: Recommended procedure for soldering finger stock to A¹ of plate-line assembly.

Note: $\frac{3}{8}$ -wide beryllium finger stock (Instrument Specialties Co., Inc., 97-136 or equivalent).

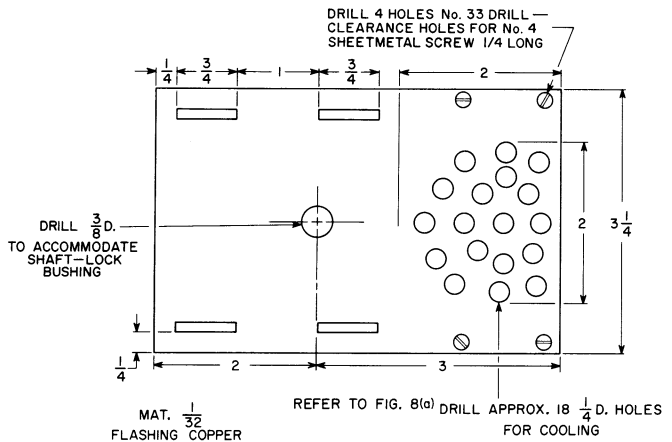

Figure 8(b): Cover for plate-line compartment showing vent holes and location of hole for coupling probe.

fier neutralization should be made as follows:

Adjust the plate-tuning capacitor, C_1 , throughout its range and observe grid-No. 1 current. No change in grid current should occur as C_1 goes through resonance. If there is any noticeable change, readjust C_3 slightly. If the condition persists, further neutralization is accomplished by insulating one or more fingers of the E. F. Johnson bypass ring from the screen-ring terminal of the tube. Small pieces of 0.010-inch-thick Teflon can be used for this purpose. Generally, no more than two fingers should have to be insulated to obtain complete neutralization. The insulation of more than two fingers can result in self-oscillation, which is indicated by excessive grid-No. 1 current.

In the next stage of the amplifier-circuit

preparation, terminate the output-coupling probe with a 50-ohm load,* and apply dc voltages to the plate and screen grid of the tube from a variable supply. Begin with 700 volts on the plate and something less than 200 volts on the screen. The plate capacitor is then tuned to resonance and the probe coupling adjusted, simultaneously, for maximum power output. Maximum power output does not necessarily occur at minimum plate current; therefore, some form of output-power measuring device is required.

At resonance with 700 volts on the plate and 200 volts on the screen grid, the power output should be approximately 100 watts.

*The 50-ohm load must be suitable for use in the 400-to-500-megacycle frequency range and capable of dissipating 300 watts of power.

The plate current should be in the range from 260 to 300 milliamperes. Grid-No. 1 current should be between 25 to 30 milliamperes. If grid-No. 1 current is found to be higher than 35 milliamperes at this point, recheck for neutralization. When the plate potential is increased to 1,500 volts, the power output will be approximately 235 watts. For a plate potential of 2,000 volts, the power output will be 300 watts for 600-watt input.

Antenna and Feedline System

The antenna and feedline used with the amplifier unit must be judiciously selected if the desired output is to be obtained without the cost of the system becoming exorbitant. A recommended arrangement that is relatively inexpensive and provides a low-loss antenna feed is described as follows:

In this arrangement, an antenna that presents a 300-ohm load impedance should be used. The main portion of the feedline, which will extend from the antenna into the "shack," can then be a low-loss, 300-ohm, open-wire line or one of the better-quality, television-transmission lines. This 300-ohm line must be connected to the amplifier through a 4-to-1 balun, which may be constructed from Rg-11/U coaxial. (For instruction on balun construction, refer to ARRL Handbook.) This balun is needed to provide the impedance

transformation of 300 to 50 ohms required to match the antenna system to the power amplifier. The advantage of this arrangement is that the length of coaxial cable used in the feed system need not be longer than 5 or 6 feet. The use of Rg-8/U cable in lengths greater than 6 feet is not recommended because of the high attenuation factor of this cable at 450 megacycles.

There are several commercially available very-low-loss, 50-ohm coaxial cables that would be highly suitable for use as antenna feedlines for the power amplifier; however, they are substantially more expensive than the more common Rg-8/U cable or open-wire type of line. A typical example of a very-low-loss, 50-ohm coaxial cable is Foam Helix, which is manufactured by the Andrew Corporation. This cable has an attenuation of only 1.25 db per 100 feet at 450 megacycles. The Rg-8/U has a loss figure of 5db per 100 feet at 450 megacycles. These figures indicate that the losses in a feedline made of Rg-8/U cable would be more than twice those in a feedline made from Foam Helix.

The importance of the type of feedline used between the amplifier and the antenna—as well as the method of its employment—cannot be emphasized too strongly. With a loss of 3 db in the feedline, only half of the tube power output will be delivered to the antenna.

Information furnished by the Radio Corporation of America is believed to be accurate and reliable. However, no responsibility is assumed by RCA for its use; nor for any in-

fringements of patents or other rights of third parties which may result from its use. No license is granted by implication or otherwise under any patent or patent rights of RCA.



From your local
RCA distributor,
headquarters for
RCA receiving
and power tubes.

RCA HAM TIPS
is published by RCA
Electronic Components
and Devices, Harrison,
N. J. It is available
free of charge from
RCA distributors.

GEORGE D. BARBEY CO., INC.
Reading Pottstown
Lancaster Lebanon

WHEN MAILING
PLACE POSTAGE HERE